

HL900NECO

air admittance valve DN110 with integrated double insulation



air admittance valve DN110 for internal venting of soil and waste systems according to EN12380-1 with removable insect screen (easy cleaning), massive rubber membrane and integrated double insulation. Supervisory approval Z-53.5-460.



techn. drawing

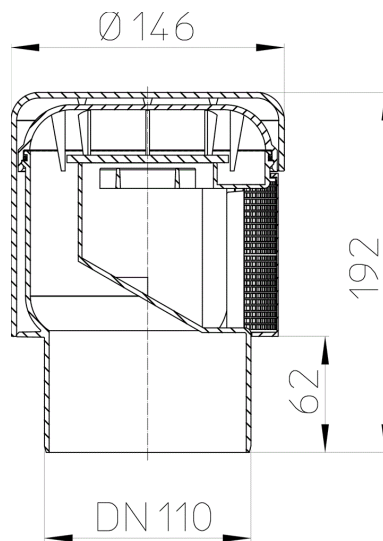

TECHNICAL DATA

material	PP	installation height	130 mm
dimension	DN110	grate frame	
capacity	37 l/s	grate	
weight	0,46	load class	

HL904

air admittance valve DN40



air admittance valve DN40 with adapter DN32/50



techn. drawing

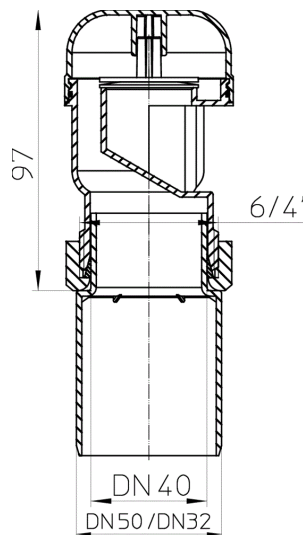

TECHNICAL DATA

material	PP	installation height	97 mm
dimension	DN32/40/50	grate frame	
capacity	5,25 l/s	grate	
weight	0,075	load class	

HL905N

Consealed air admittance valve



Air admittance valve for in-wall installation. Including lot cover, removable function cartridge and cover.



techn. drawing

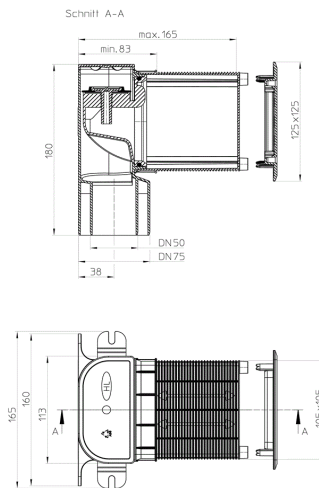

TECHNICAL DATA

material	PP/ABS	installation height
dimension	DN50/75	grate frame
capacity	13 U/s	grate
weight	0,383	load class
EAN	9003076049752	inlet